

E-QP-8VE0850MPCH-FC

40GbE and Infiniband, 850nm, 40GBASE-SR4, MPO, 0°~ 70°C
QSFP+ SR4 Transceiver



Model Name	Voltage	Category	Device type	Interface	Temperature	Distance
E-QP-8VE0850MPCH-FC	3.3V	With DDMI	850 nm VCSEL	CML/CML	0°C~+ 70°C	100m /150m (OM3/OM4)

Purpose

40-Gbps QSFP+ Parallel Optical Transceiver Module. However, this document is not fully complete yet, therefore, this datasheet only provides basic information and electronic characteristics. This document is for customer's reference only, and it subjects to change without notice.

Description

Quad Small Form-factor Pluggable Plus (QSFP+) product is a new high speed pluggable I/O interface products. This interconnecting system offers 4 channels and maximum bandwidth of 40Gbps which are based on the proprietary technique Silicon Optical Bench (SiOB) as an optical engine. This module provides high performance and excellent efficiency in the short-reach (SR) optical interconnects.

Features

- Compliant with 40G Ethernet IEEE 802.3ae 40GBASE-SR4 standards
- Compliant to SFF-8436 QSFP+ Specification Revision 4.0
- Supports 40 Gbps data rate links of up to 150 m
- Low power consumption of max 1.5 W Power Level 1 compliance
- Hot pluggable electrical interface
- Using standard 12/8 lane optical fiber with MPO pluggable optical connector.
- 0 to 70°C case temperature operating range
- RoHS-6 Compliant (lead-free)

Applications

- 40GBASE-SR4 Ethernet links
- Infiniband QDR and DDR interconnects
- 4G/8G/10G Fiber Channel
- SATA/SAS Storage
- HPC Interconnects
- Client-side 40G Telecom connections

Absolute Maximum Rating

Not necessarily applied together. Exceeding these values may cause permanent damage. Functional operation under these conditions is not implied.

Parameter	Symbol	Min	Typical	Max	Unit	Note
Storage Temperature	Ts	-40		100	°C	
3.3V Power Supply Voltage	Vcc	-0.5		3.6	V	
Data Input Voltage-Single Ended		-0.5		V _{CC} +0.5	V	
Data Input Voltage-Single Ended	V _{DIP} -V _{DIN}			1.0	V	
Relative Humidity	RH	5		85	%	

Recommended Operating Conditions

Parameter	Symbol	Min	Typical	Max	Unit	Note
Case Temperature	Tc	0	40	70	°C	
3.3 V Power Supply Voltage	Vcc	3.135	3.3	3.465	V	
Signal Rate per Channel		2.5		10.3125	Gbps	
Control* Input Voltage High	Vih	2		V _{CC} +3	V	
Control* Input Voltage Low	Vil	- 0.3		0.8	V	
Two Wire Serial (TWS) Interface Clock Rate				400	kHz	
Receiver Differential Data Output Load			100		Ohms	
Fiber Length: 2000 MHz·km 50µm MMF (OM3)		0.5		100	m	
Fiber Length: 4700 MHz·km 50µm MMF (OM4)		0.5		150	m	

Transceiver Electrical Characteristics

The following characteristics are defined over the Recommended Operating Conditions unless otherwise noted. Typical values are for Tc = 40°C, Vcc = 3.3 V.

Parameter	Symbol	Min	Typical	Max	Unit	Note
10G Transceiver Power Consumption				1.5	W	
Transceiver Power Supply Current				420	mA	
Transceiver Power On Initialization Time	tpwr init			2000	ms	1.

Notes:

1. "Initialization Time" is the time from when the supply voltages reach and remain above the minimum "Recommended Operating Conditions" to the time when the module enables TWS access. The module at that point is fully functional.

Electrical Characteristics

Parameter	Symbol	Min	Typical	Max	Unit	Note
Transmitter Electrical Characteristics						
Data Input Differential Peak-to-Peak Voltage Swing	ΔVDI_{PP}	175		1600	mVpp	
LOS Assert Threshold: Tx Data Input Differential Peak-to-Peak Voltage Swing	ΔVDI_{PP_LOS}	50			mVpp	
Differential input threshold			50		mV	
Receiver Electrical Characteristics						
Data Output Differential Peak-to-Peak Voltage Swing (AC-Coupled)	ΔVDO_{pp}	200		900	mVpp	
Output transition time 20% to 80%	t_rise, t_fall	28			ps	
Output Total Jitter				62	ps	

Optical Characteristics

Parameter	Symbol	Min	Typical	Max	Unit	Note
Transmitter Electrical Characteristics						
Center Wavelength	λ	840		860	nm	
Spectral Width - RMS	λ			0.65	nm	
Output Optical Power: Average	PO_AVE	-7.6		2.4	dBm	
Output Optical Modulation Amplitude, per lane		-5.6		3	dBm	
Extinction Ratio	ER	3			dB	
Output Optical Power: Disabled	PO_OFF			-30	dBm	
Eye Mask		Compliant with IEEE 802.3ba D3.2				
Receiver Electrical Characteristics						
Center wavelength, each lane	λ	840	850	860	nm	
Damage Threshold		3.4			dBm	
Maximum Average power at receiver input, each lane				2.4	dBm	
Receiver Reflectance				-12	dB	
Stressed receiver sensitivity (Avg)				-5.4	dBm	1
LOS Assert		-30			dB	
LOS De-Assert				-7.5	dB	
LOS Hysteresis		0.5			dB	

Notes:

1. Measured with 10.3125-Gbps of PRBS-31 at 10^{-12} BER.

QSFP+ Module Pad Assignments and Descriptions

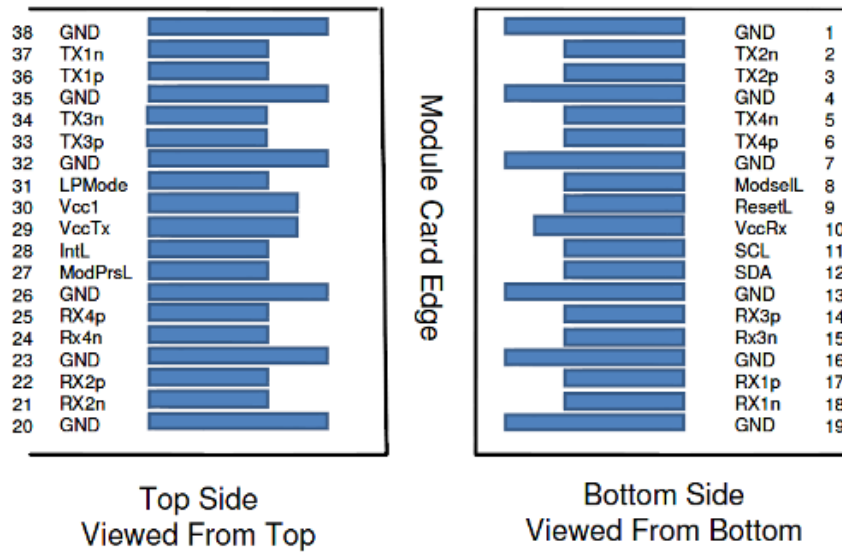

Pin	Logic	Symbol	Description	Plug Sequence	Notes
1		GND	Ground	1	1
2	CML-I	Tx2n	Transmitter Inverted Data Input	3	
3	CML-I	Tx2p	Transmitter Non-Inverted Data Input	3	
4		GND	Ground	1	1
5	CML-I	Tx4n	Transmitter Inverted Data Input	3	
6	CML-I	Tx4p	Transmitter Non-Inverted Data Input	3	
7		GND	Ground	1	1
8	LVTTL-I	ModSelL	Module Select	3	
9	LVTTL-I	ResetL	Module Reset	3	
10		Vcc Rx	+3.3V Power Supply Receiver	2	2
11	LVC MOS-I/O	SCL	2-wire serial interface clock	3	
12	LVC MOS-I/O	SDA	2-wire serial interface data	3	
13		GND	Ground	1	2
14	CML-O	Rx3p	Receiver Non-Inverted Data Output	3	
15	CML-O	Rx3n	Receiver Inverted Data Output	3	
16		GND	Ground	1	1
17	CML-O	Rx1p	Receiver Non-Inverted Data Output	3	
18	CML-O	Rx1n	Receiver Inverted Data Output	3	
19		GND	Ground	1	1
20		GND	Ground	1	1
21	CML-O	Rx2n	Receiver Inverted Data Output	3	
22	CML-O	Rx2p	Receiver Non-Inverted Data Output	3	
23		GND	Ground	1	1
24	CML-O	Rx4n	Receiver Inverted Data Output	3	
25	CML-O	Rx4p	Receiver Non-Inverted Data Output	3	
26		GND	Ground	1	1
27	LVTTL-O	ModPrsL	Module Present	3	
28	LVTTL-O	IntL	Interrupt	3	
29		Vcc Tx	+3.3V Power supply transmitter	2	2

Pin	Logic	Symbol	Description	Plug Sequence	Notes
30		Vcc1	+3.3V Power supply	2	2
31	LVTTTL-I	LPMODE	Low Power Mode	3	
32		GND	Ground	1	1
33	CML-I	Tx3p	Transmitter Non-Inverted Data Input	3	
34	CML-I	Tx3n	Transmitter Inverted Data Input	3	
35		GND	Ground	1	1
36	CML-I	Tx1p	Transmitter Non-Inverted Data Input	3	
37	CML-I	Tx1n	Transmitter Inverted Data Input	3	
38		GND	Ground	1	1

Notes:

- 1: GND is the symbol for signal and supply (power) common for the QSFP+ module. All are common within the QSFP+ module and all module voltages are referenced to this potential unless otherwise noted. Connect these directly to the host board signal-common ground plane.
- 2: Vcc Rx, Vcc1 and Vcc Tx are the receiver and transmitter power supplies and shall be applied concurrently. Requirements defined for the host side of the Host Edge Card Connector are listed in Table . Recommended host board power supply filtering is shown in Figure . Vcc Rx Vcc1 and Vcc Tx may be internally connected within the QSFP+ module in any combination. The connector pins are each rated for a maximum current of 500 mA.

Recommended Host Board Power Supply Circuit

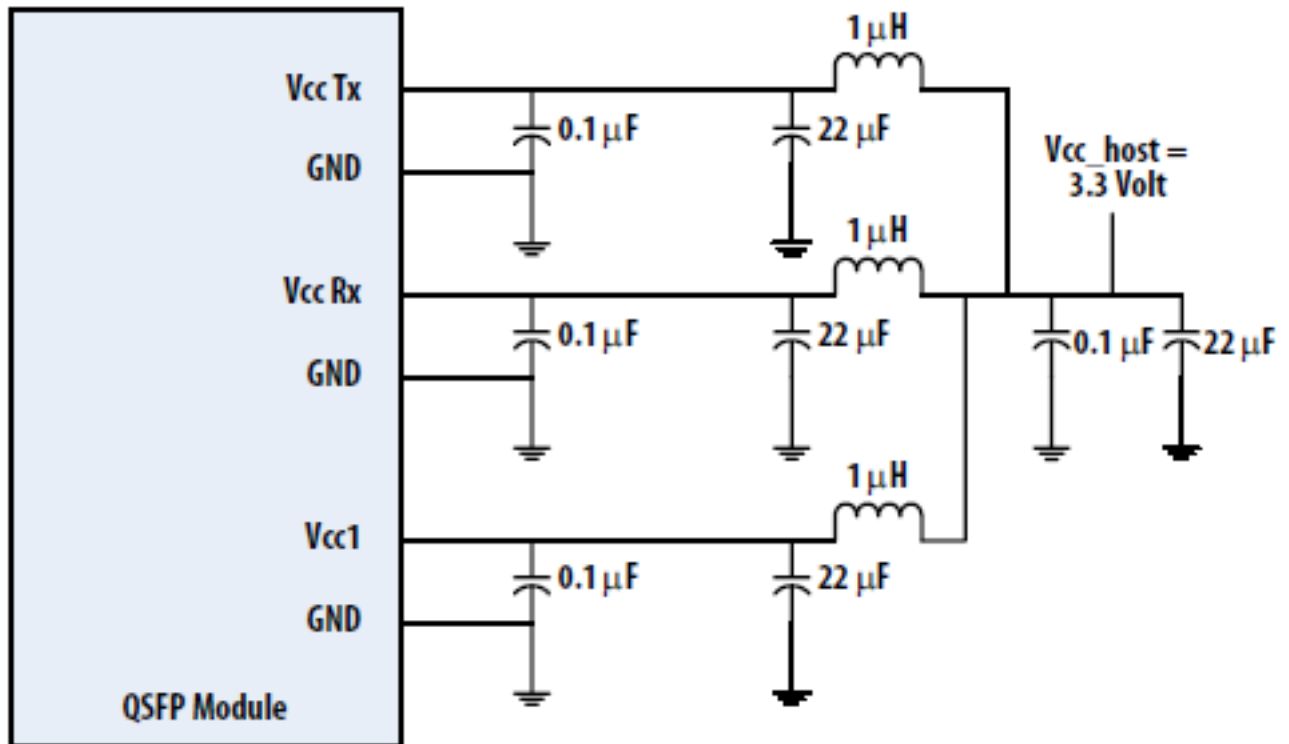

Recommended Interface Circuit

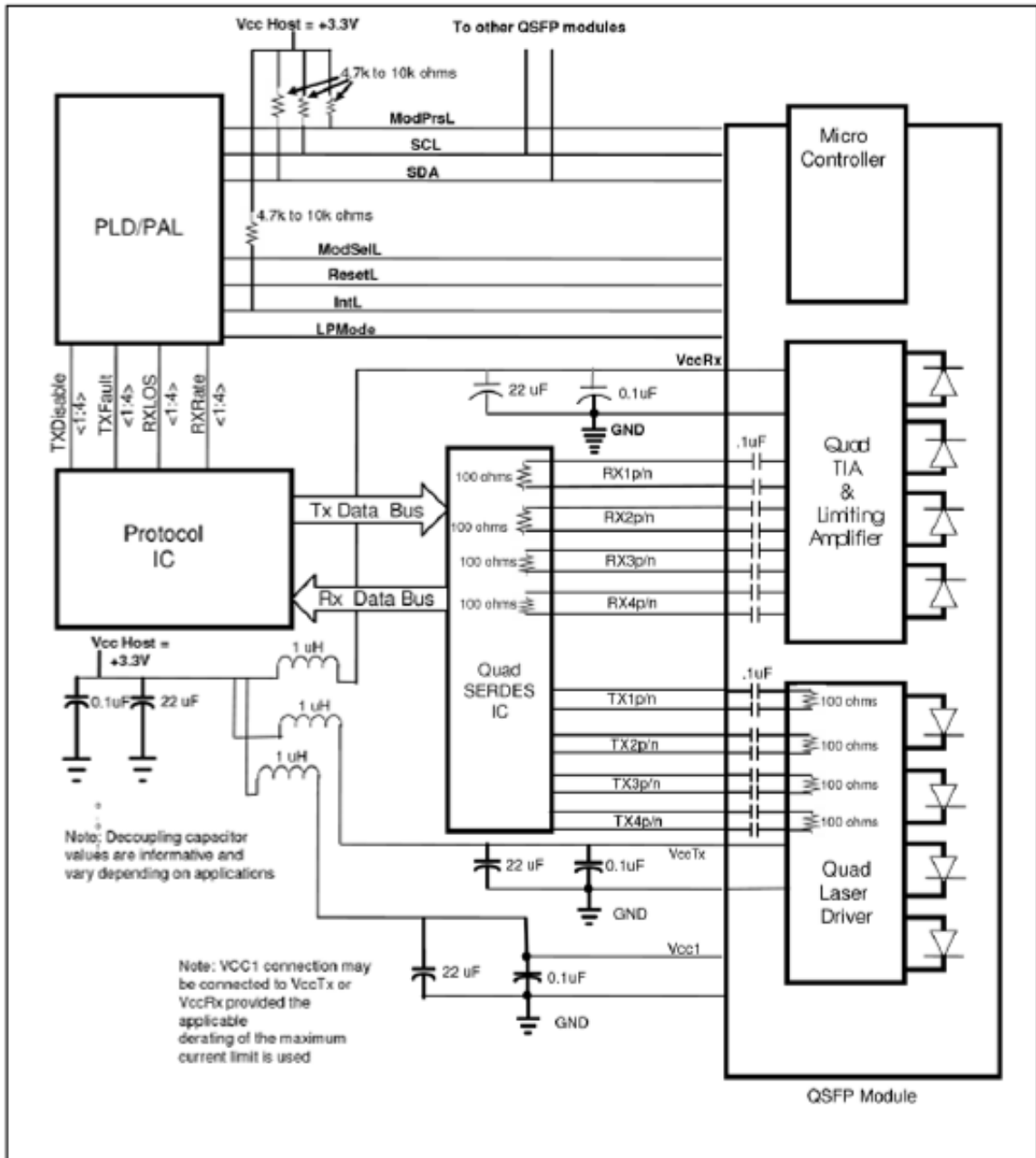

Memory Map

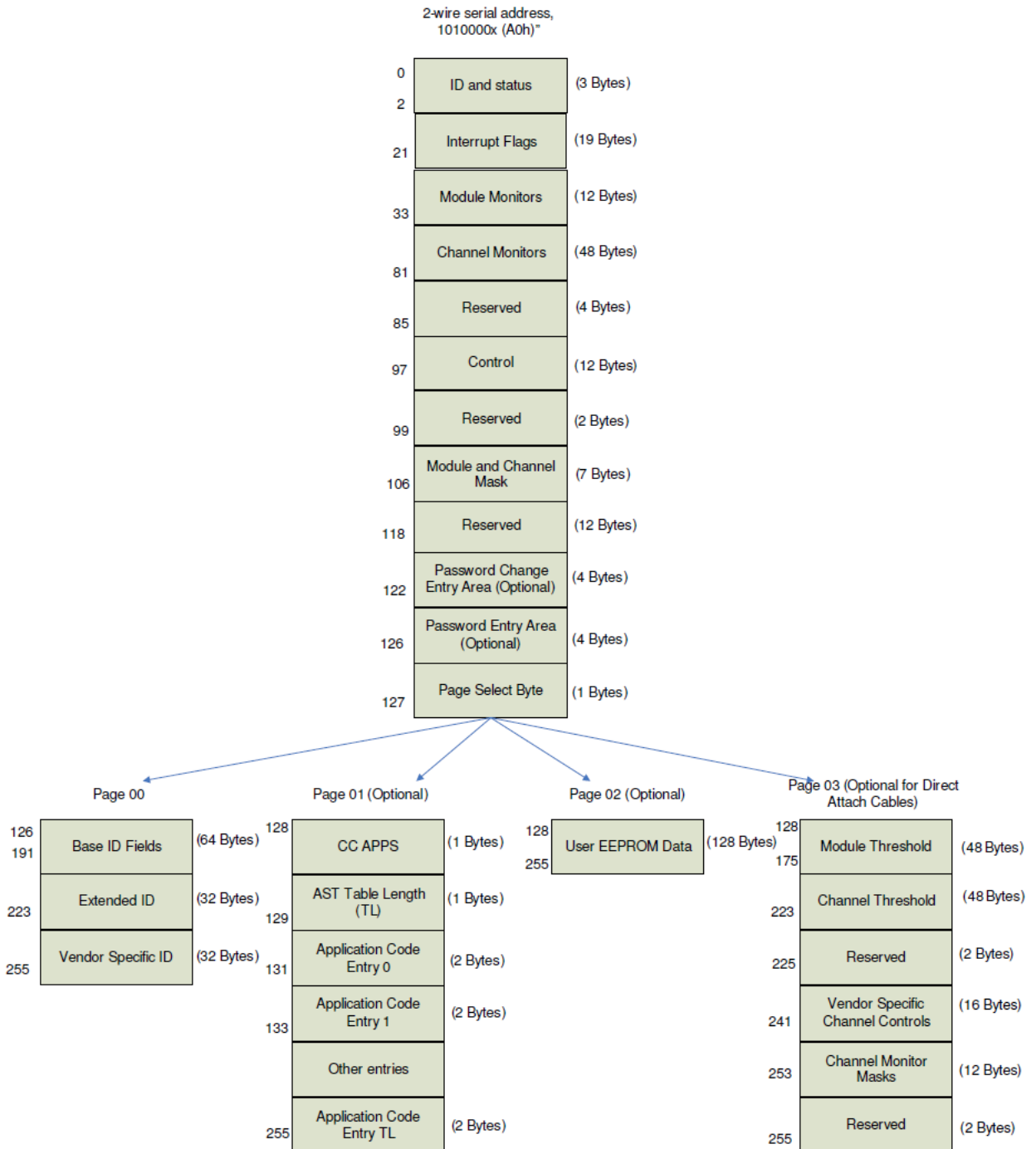

Contention 2-Wire Address A0H

Address	Description	Default/Typical value
0	Identifier	0D
1	Reserved	00
2	Status	02
3	Rx LOS	00
4	Tx Fault	00
6	Temp High/Low alarm/warning	00
7	Vcc high/low alarm/ warning	00
22-25	Reserved	00
26-27	Supply voltage	
28-41	Reserved	00
42-49	Tx bias	
50-85	Reserved	00
86	Tx disable	00
87-106	Reserved	00
100-106	Module and ChannelMasks	
107-118	Reserved	00
119-122	Password Change EntryArea (optional)	
123--126	Password Entry Area (optional)	
127	Page Select Byte	00

Address	Description	Hex	Real Value
128	Identifier	0D	QSFP+
129	Ext. Identifier Connector	00	Power Class 1 Module; No CLEI code present in Page 02h; No CDR in TX and RX
130	Connector	0C	MPO Connector
131	Specification Compliance	04	40GBASE-SR4
132		00	Not compliant
133		00	Not compliant
134		01	1000BASE-SX
135		40	Short distance (S)
136		40	Shortwave laser w/o OFC (SN)
137		06	Multi-Mode 50m (M5)/50um (OM3)
138		00	Not compliant
139	Encoding	05	64B66B
140	BR, nominal	64	10.0Gbps
141	Extended rate select Compliance	00	Not compliant
142	Length(SMF)	00	Not compliant
143	Length(OM3 50 um)	32	100M
144	Length (OM2 50 um)	1E	30M
145	Length(OM1 62.5 um)	00	Not compliant
146	Length(Copper)	00	30M
147	Device tech	00	850nm VCSEL; No wavelength control; Uncooled transmitter device; Pin detector; Transmitter not tunable
148-163	Vendor name	46,4F,52,4D,45,52,49,43 41,4F,45,20,20,20,20,20	
164	Extended Module	04	QDR
165-167	Vendor OUI	00, 00, 00	
168-183	Vendor PN	54,51,53,2D,51,31,4C,48, 39,2D,32,43,41,20,20,20	E-QP-8VE085MPCH-FC
184-185	Vendor rev	20,20	
186-187	Wave length or Copper cable Attenuation	42,68	850nm
188-189	Wavelength tolerance	07,D0	±10nm
190	Max case temp.	46	70 °C
191	CC_BASE		Check sum of byte 128 ~ 190
192-195	Options	00, 00, 00,00	
196-211	Vendor SN		
212-219	Date Code		
220	Diagnostic Monitoring Type	08	Average Power
221	Enhanced Options	00	
222	Reserved	00	
223	CC_EXT		Check sum of byte 192 ~ 222
224-225	Vendor Specific		

Address	Description	Hex	Real Value
128-129	Temp high alarm	50,00	80°C
130-131	Temp low alarm	FB,00	-5°C
132-133	Temp high warning	4B,00	75°C
134-135	Temp low warning	00,00	0°C
144-145	Vcc high alarm	8C, A0	3.6V
146-147	Vcc low alarm	75, 30	3.0V
148-149	Vcc high warning	88, B8	3.5V
150-151	Vcc low warning	79, 18	3.1V
176-177	Rx power high alarm	61, A8	4.0dBm
178-179	Rx power low alarm	08, FC	-6.4dBm
180-181	Rx power high warning	55, 28	3.4dBm
182-183	Rx power low warning	0B, 40	-5.4dBm
184-185	Tx bias high alarm	30, D4	25mA
186-187	Tx bias low alarm	03, E8	2mA
188-189	Tx bias high warning	2C, EC	23mA
190-191	Tx bias low warning	07, D0	4mA

Mechanical Design Diagram

Unit: mm

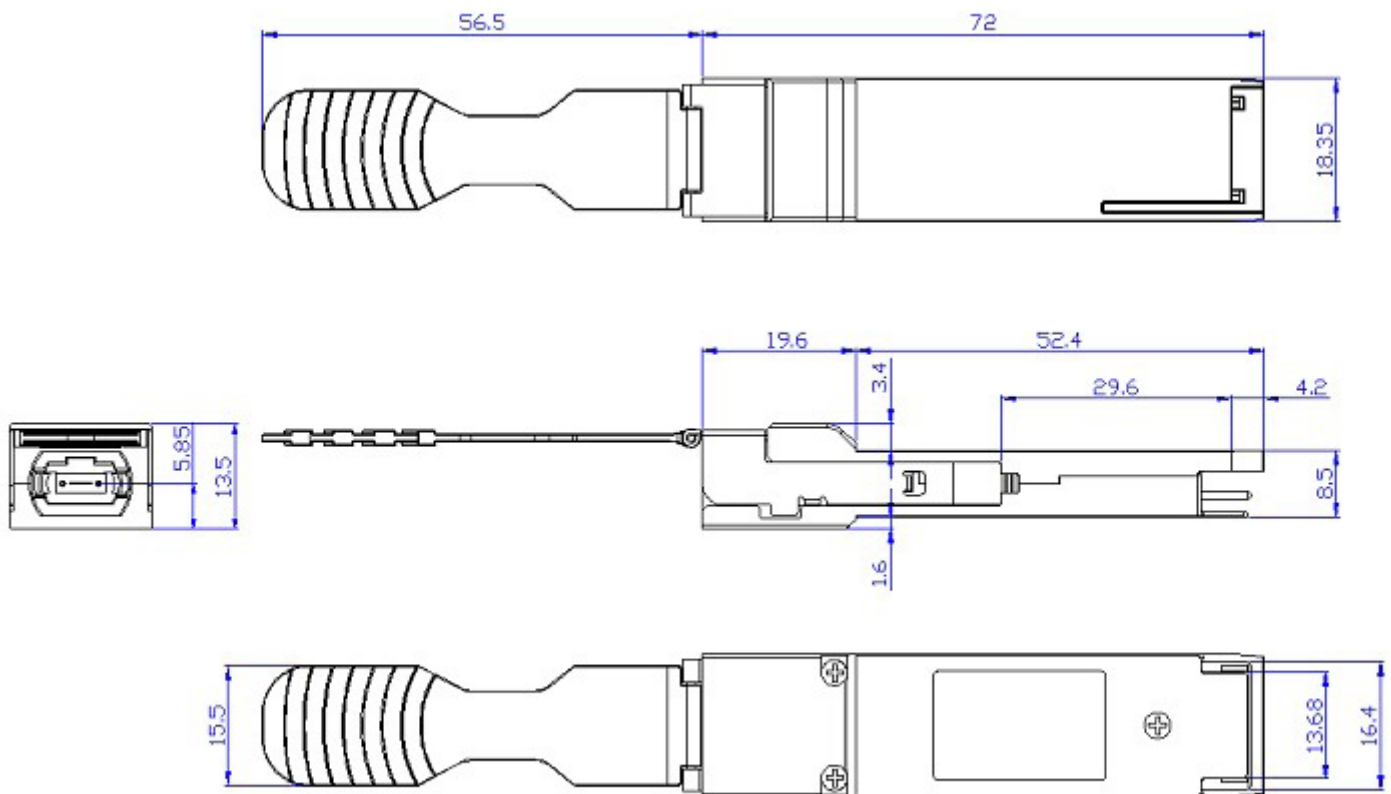

For product information and a complete list of cloud computing and data center related products, please go to our website: www.foci.com.tw
Data subject to change. FOCI-40-Gbps-QSFP+SR4-DATASHEET-29-05-2015.

FOCI Fiber Optic Communications, Inc.
No.18, Prosperity Rd. II, Science-Based Industrial Park,
Hsinchu, 300, Taiwan, R.O.C.
Tel:+886-3-5770099; Fax:+886-3-5799766
email: sales@mail.foci.com.tw



Ordering Information:

E - - -

Model Type

SP	SFP Transceivers
CS	CWDM SFP Transceivers
DS	DWDM SFP Transceivers
XP	XFP Transceivers
CX	CWDM XFP Transceivers
DX	DWDM XFP Transceivers
DT	Tunable DWDM XFP Transceivers
SS	SFP+Transceivers
CP	CWDM SFP+Transceivers
DP	DWDM SFP+Transceivers
QP	QSFP+Transceivers
QC	CWDM QSFP+Transceivers

Speed Type

B	4.0 Gbps	7	10 Gbps
5	1.25 Gbps	8	40 Gbps
6	2.5 Gbps	9	100 Gbps
		X	others, please specify

Laser Type

D	DFB Laser
E	LED
L	FP Laser
V	VCSEL

Power Supply

A	5V/TTL	E	3.3V/TTL
C	3.3V/5V/TTL	O	3.3V/5V/PECL
D	5V/PECL	V	3.3V/PECL

Wavelength

0850	850nm
1310	1310nm
1550	1550nm
1315	TX1310nm/RX1550nm
XXXX	others, please specify

Temperature Range

C	Commercial (0°C to 70°C)
I	Industrial (-40°C to 85°C)
X	others, please specify

Checking Code

F	G	P
---	---	---

Distance

C	5 km	1	10 km
D	2 km	2	20 km
E	500 m	4	40 km
F	550 m	5	50 km
G	100 m	6	60 km
H	150 m	8	80 km
I	300 m	9	90 km
		X	others, please specify

Fiber Type

A	SMF 9/125um Single-Mode
C	50/125um Multi-Mode
D	62.5/125um Multi-Mode

Connector Type

SC	SC
FC	FC
ST	ST
LC	LC
MP	MPO

